



Optical reading head PXV100-F200-B25-V1D

- EtherNet/IP
- Non-contact positioning on Data Matrix code tape
- Mechanically rugged: no wearing parts, long operating life, maintenance-free
- High resolution and precise positioning, especially for facilities with curves and switch points as well as inclines and declines.
- Integrated switch
- Travel ranges up to 10 km

Read head for incident light positioning system



Dimensions

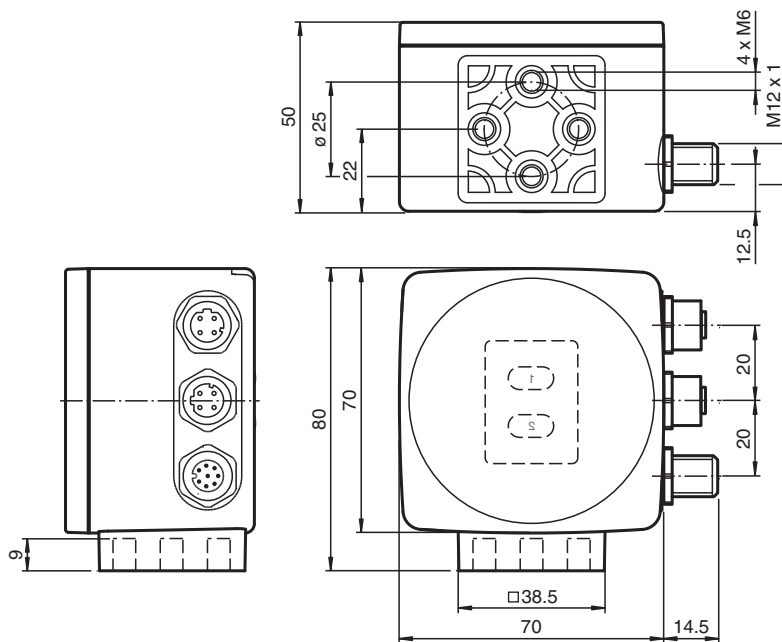

Technical Data

General specifications

Passage speed	v	≤ 8 m/s
Measuring range		max. 10000 m
Light type		Integrated LED lightning (red)
Scan rate		40 s ⁻¹
Read distance		100 mm
Depth of focus		± 50 mm
Reading field		115 mm x 73 mm
Ambient light limit		100000 Lux

Release date: 2020-04-06 Date of issue: 2020-06-05 Filename: 293431-100004_eng.pdf

Refer to "General Notes Relating to Pepperl+Fuchs Product Information".

Pepperl+Fuchs Group
www.pepperl-fuchs.com

USA: +1 330 486 0001
fa-info@us.pepperl-fuchs.com

Germany: +49 621 776 1111
fa-info@de.pepperl-fuchs.com

Singapore: +65 6779 9091
fa-info@sg.pepperl-fuchs.com

PF PEPPERL+FUCHS

Technical Data

Accuracy	± 0.2 mm		
Nominal ratings			
Camera			
Type	CMOS , Global shutter		
Processor			
Clock pulse frequency	600 MHz		
Speed of computation	4800 MIPS		
Functional safety related parameters			
MTTF _d	103 a		
Mission Time (T _M)	20 a		
Diagnostic Coverage (DC)	0 %		
Indicators/operating means			
LED indication	7 LEDs (communication, alignment aid, status information)		
Electrical specifications			
Operating voltage	U _B	15 ... 30 V DC , PELV	
No-load supply current	I ₀	max. 400 mA	
Power consumption	P ₀	6 W	
Interface			
Interface type	100 BASE-TX		
Protocol	EtherNet/IP		
Transfer rate	100 MBit/s		
Interface 2			
Interface type	USB Service		
Input			
Input type	1 function input 0-level: -U _B or unwired 1-level: +8 V ... +U _B , programmable		
Input impedance	≥ 27 kΩ		
Output			
Output type	1 to 3 switch outputs , programmable , short-circuit protected		
Switching voltage	Operating voltage		
Switching current	150 mA each output		
Standard conformity			
Emitted interference	EN 61000-6-4:2007+A1:2011		
Noise immunity	EN 61000-6-2:2005		
Shock resistance	EN 60068-2-27:2009		
Vibration resistance	EN 60068-2-6:2008		
Approvals and certificates			
UL approval	cULus Listed, General Purpose, Class 2 Power Source, Type 1 enclosure		
CCC approval	CCC approval / marking not required for products rated ≤36 V		
Ambient conditions			
Operating temperature	0 ... 60 °C (32 ... 140 °F) , -20 ... 60 °C (-4 ... 140 °F) (noncondensing; prevent icing on the lens!)		
Storage temperature	-20 ... 85 °C (-4 ... 185 °F)		
Relative humidity	90 % , noncondensing		
Mechanical specifications			
Connection type	8-pin, M12x1 connector, standard (supply+IO) 4-pin, M12x1 socket, D-coded (LAN) 4-pin, M12x1 socket, D-coded (LAN)		
Housing width	70 mm		
Housing height	70 mm		
Housing depth	50 mm		
Degree of protection	IP67		
Material			
Housing	PC/ABS		

Release date: 2020-04-06 Date of issue: 2020-06-05 Filename: 293431-100004_eng.pdf

Refer to "General Notes Relating to Pepperl+Fuchs Product Information".

Pepperl+Fuchs Group
www.pepperl-fuchs.com

USA: +1 330 486 0001
fa-info@us.pepperl-fuchs.com

Germany: +49 621 776 1111
fa-info@de.pepperl-fuchs.com

Singapore: +65 6779 9091
fa-info@sg.pepperl-fuchs.com

 **PEPPERL+FUCHS**

Technical Data

Mass approx. 200 g

Connection

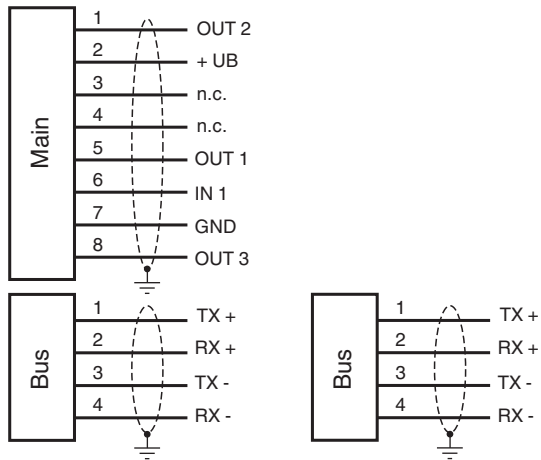

Connection Assignment

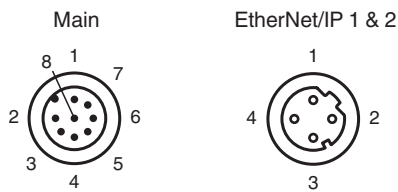

Function Principle

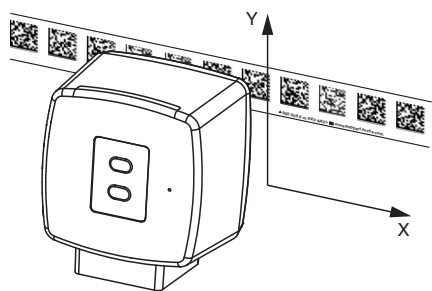

Position Data



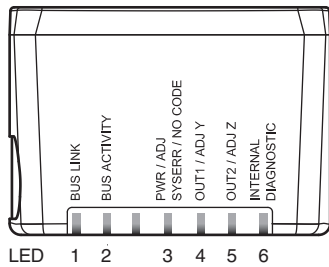
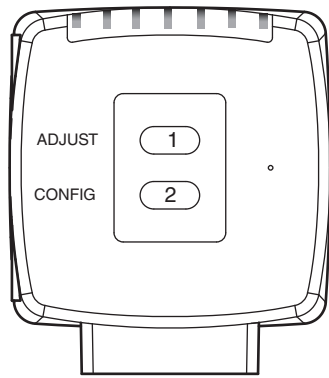







Release date: 2020-04-06 Date of issue: 2020-06-05 Filename: 293431-100004_eng.pdf



Matching system components









	PXV*-CA25-*	Data Matrix code tape
	VPH-F200-T	Climate control housing to extend the temperature range of the sensor used

Accessories

	PCV-SC12	Grounding clip for PCV system
	PCV-LM25	Marker head for 25 mm code tape
	V1SD-G-2M-PUR-ABG-V1SD-G	Ethernet bus cable, M12 to M12, PUR cable 4-pin, CAT5e
	V1SD-G-5M-PUR-ABG-V1SD-G	Ethernet bus cable, M12 to M12, PUR cable 4-pin, CAT5e
	PCV-AG100	Alignment guide for PCV100-* read head
	PCV-MB1	Mounting bracket for PCV* read head
	V19-G-ABG-PG9-FE	Female connector, M12, 8-pin, shielded, field attachable
	V19-G-ABG-PG9	Female connector, M12, 8-pin, shielded, field attachable
	PCV-SC12A	Grounding clip for PCV system

Release date: 2020-04-06 Date of issue: 2020-06-05 Filename: 293431-100004_eng.pdf

Accessories

	V19-G-2M-PUR-ABG	Female cordset, M12, 8-pin, shielded, PUR cable
	V19-G-5M-PUR-ABG	Female cordset, M12, 8-pin, shielded, PUR cable
	V1SD-G-5M-PUR-ABG-V45-G	Connection cable, M12 to RJ-45, PUR cable 4-pin, CAT5e
	V1SD-G-30M-PUR-ABG-V45-G	Connection cable, M12 to RJ-45, PUR cable 4-pin, CAT5e
	V1SD-G-2M-PUR-ABG-V45-G	Connection cable, M12 to RJ-45, PUR cable 4-pin, CAT5e
	V1SD-G-10M-PUR-ABG-V45-G	Connection cable, M12 to RJ-45, PUR cable 4-pin, CAT5e
	Vision Configurator	Operating software for camera-based sensors
	PCV-KBL-V19-STR-USB	USB cable unit with power supply
	PXV-CM25-*-*-SET	Event Marker for PXV system

Additional Information

General

The reading head is part of the positioning system in the method for measurement by Pepperl+Fuchs. It consists of a camera module and an integrated illumination unit among other things. The reading head detects position marks, which are put on an adhesive code band in the form of Data Matrix code. The mounting of the code band is as a rule stationary on a firm part of the plant (elevator shaft, overhead conveyor mounting rails...); that of the reading head is parallel on the moving "vehicle" (elevator car, overhead conveyor chassis...).

Mounting and commissioning

Mount the reading head such that its optical surface captures the optimal read distance to the code band (see Technical Data). The stability of the mounting and the guidance of the vehicle must be provided such that the depth of field of the reading head is not closed during operation. All reading heads can be optimally customized by parameterization for specific requirements.

Displays and Controls

The reading head allows visual function check and fast diagnosis with 6 indicator LEDs. The reading head has 2 buttons on the reverse of the device to activate the alignment aid and parameterization mode.

LEDs

LED	Color	Label	Meaning
1	green	BUS LINK	Communication status
2	yellow	BUS ACTIVITY	Data transfer
3	red / green	PWR / ADJ SYSERR / NO CODE	Code recognized / not recognized, Error
4	yellow	OUT1/ADJ Y	Output 1, Alignment aid Y
5	yellow	OUT2/ADJ Z	Output 2, Alignment aid Z
6	red/green/yellow	INTERNAL DIAGNOSTIC	Internal diagnostics

Alignment aid for the Y and Z coordinates

The activation of the alignment aid is only possible within 10 minutes of switching on the reading head. The switchover from normal operation to "alignment aid operating mode" is via button 1 on the reverse of the reading head.

- Press the button 1 for longer than 2 s. LED3 flashes green for a recognized code band. LED3 flashes red for an unrecognized code band.
- **Z coordinate:** If the distance of the camera to the code band is too small, the yellow LED5 lights up. If the distance of the camera to the code band is too large, the yellow LED5 lights up. Within the target range, the yellow LED5 flashes at the same time as the green LED3.
- **Y coordinate:** If the optical axis of the camera is too deep in relation to the middle of the code band, the yellow LED4 lights up. If the optical axis is too high, the yellow LED4 extinguishes. Within the target range, the yellow LED4 flashes at the same time as the green LED3.
- A short press on button 1 ends the alignment aid and the reading head changes to normal operation.